

HAE200 SERIES

HALF-BRICK DC-DC CONVERTER

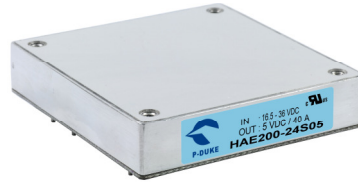

2:1 WIDE INPUT RANGE
UP TO 255Watts



FEATURES

- NO MINIMUM LOAD REQUIRED
- 2250VDC INPUT TO OUTPUT BASIC INSULATION
- UL60950-1, EN60950-1, & IEC60950-1 SAFETY APPROVALS
- CE MARKED
- COMPLIANT TO RoHS II & REACH

APPLICATIONS

- WIRELESS NETWORK
- TELECOM/DATACOM
- INDUSTRY CONTROL SYSTEM
- DISTRIBUTED POWER ARCHITECTURES
- SEMICONDUCTOR EQUIPMENT

2250VDC ISOLATION	REMOTE CONTROL	UVP	OCP	SCP	OVP	OTP	SYNC
-------------------	----------------	-----	-----	-----	-----	-----	------

TECHNICAL SPECIFICATION

All specifications are typical at nominal input, full load and 25°C otherwise noted

Model Number	Input Range	Output Voltage	Output Current @Full Load	Input Current @ No Load	Efficiency	Maximum Capacitor Load
	VDC	VDC	A	mA		
HAE200-12S3P3	9 ~ 22	3.3	50	25	87	151000
HAE200-12S05	9 ~ 22	5	36	90	90	72000
HAE200-12S12	8.5 ~ 22	12	15	90	90	12500
HAE200-12S15	8.5 ~ 22	15	12	55	90	8000
HAE200-12S24	8.5 ~ 22	24	7.5	70	90	3100
HAE200-12S28	8.5 ~ 22	28	6.5	55	90	2300
HAE200-12S48	8.5 ~ 22	48	3.7	75	89	770
HAE200-24S3P3	16.5 ~ 36	3.3	50	20	88	151000
HAE200-24S05	16.5 ~ 36	5	40	35	91	80000
HAE200-24S12	16.5 ~ 36	12	18	45	91	15000
HAE200-24S15	16.5 ~ 36	15	15	45	91	10000
HAE200-24S24	16.5 ~ 36	24	9	40	93	3700
HAE200-24S28	16.5 ~ 36	28	7.5	50	93	2600
HAE200-24S48	16.5 ~ 36	48	4.5	50	91	930
HAE200-48S3P3	33 ~ 75	3.3	60	20	90	181000
HAE200-48S05	33 ~ 75	5	46	20	91	92000
HAE200-48S12	33 ~ 75	12	21	25	91	17500
HAE200-48S15	33 ~ 75	15	17	25	93	11300
HAE200-48S24	33 ~ 75	24	10.5	25	92	4300
HAE200-48S28	33 ~ 75	28	9	25	92	3200
HAE200-48S48	33 ~ 75	48	5.2	25	92	1000
HAE200-48S53	33 ~ 75	53	4.7	25	92	880

PART NUMBER STRUCTURE

Series Name	Input Voltage (VDC)	Output Quantity	Output Voltage (VDC)	Ctrl and Pin Options	SYNC pin Option	CASE pin Option	Through hole type ⁽¹⁾	Assembly Option
HAE200-48S05-PYCHS	12:9~22 8.5~22 24:16.5~36 48:33~75	S:Single	3P3:3.3 05:5 12:12 15:15 24:24 28:28 48:48 53:53	□:Negative logic, 0.200" pin length L:Negative logic, 0.145" pin length P:Positive logic, 0.200" pin length S:Positive logic, 0.145" pin length	□:NC Y:SYNC pin	□:NC C:CASE pin	□: Thread TH: No thread	□: No Heat-sink Heat-sink type: HS: Height H=0.45" vertical fin, 7G-0021A-F HS1: Height H=0.24" horizontal fin, 7G-0022A-F HS2: Height H=0.24" vertical fin, 7G-0023A-F HS3: Height H=0.45" horizontal fin, 7G-0024A-F Terminal block type⁽²⁾: T: Wall mounted TF: Wall mounted with EMC filter ⁽³⁾ TF1: Wall mounted with EMC filter can be connected to PE ⊕ ⁽³⁾

(1) The module can't equip Heat-sink with TH option.

(2) No Y and C function for terminal block type, and terminal block type only for 0.200" pin length.

(3) EMI filter meet EN55022 Class A.

INPUT SPECIFICATIONS

Parameter	Conditions		Min.	Typ.	Max.	Unit
Operating input voltage range		12Vin(nom) 3.3 & 5Vout Others	9	12	22	VDC
		24Vin(nom)	8.5	12	22	
		48Vin(nom)	16.5	24	36	
Start up voltage		12Vin(nom)			9	VDC
		24Vin(nom)			18	
		48Vin(nom)			34	
Shutdown voltage		12Vin(nom)	7.3		8.1	VDC
		24Vin(nom)	15.5		16.3	
		48Vin(nom)	31.6		32.5	
Start up time	Constant resistive load	Power up Remote ON/OFF		75 75		ms
Input surge voltage	1 second, max.	12Vin(nom)			30	
		24Vin(nom)			50	
		48Vin(nom)			100	
Input filter ⁽¹⁾					Pi type	
Remote ON/OFF	Referred to -Vin pin	Negative logic DC-DC ON (Standard) DC-DC OFF			Short or 0 ~ 1.2VDC Open or 3 ~ 12 VDC	mA
		Positive logic DC-DC ON (Option) DC-DC OFF			Short or 0 ~ 1.2VDC	
		Input current of Ctrl pin	-0.5		1	
		Remote off input current		3		
Sync pin signal ⁽²⁾			-0.3		5.6	VDC

OUTPUT SPECIFICATIONS

Parameter	Conditions		Min.	Typ.	Max.	Unit
Voltage accuracy			-1.0		+1.0	%
Line regulation	Low Line to High Line at Full Load		-0.1		+0.1	%
Load regulation	No Load to Full Load		-0.1		+0.1	%
Voltage adjustability	Maximum output deviation is inclusive of remote sense		-20		+10	%
Remote sense	% of Vout(nom)				10	%
	If remote sense is not being used, Sense pins should be connected to corresponding polarity OUTPUT pins.					
Ripple and noise	Measured by 20MHz bandwidth					mVp-p
	With a 1 μ F/25V X7R MLCC and a 22 μ F/25V POS-CAP	3.3Vout, 5Vout			75	
	With a 1 μ F/25V X7R MLCC and a 22 μ F/25V POS-CAP	12Vout, 15Vout			100	
	With a 4.7 μ F/50V X7R MLCC	24Vout, 28Vout			200	
	With a 2.2 μ F/100V X7R MLCC	48Vout, 53Vout			300	
Temperature coefficient			-0.02		+0.02	%/°C
Transient response recovery time	25% load step change			200	250	μ s
Over voltage protection	% of Vout(nom); Hiccup mode		115		130	%
Over load protection	% of Iout rated; Hiccup mode		120		150	%
Short circuit protection						Continuous, automatic recovery

GENERAL SPECIFICATIONS

Parameter	Conditions		Min.	Typ.	Max.	Unit
Isolation voltage	1 minute (Basic insulation)	Input to Output	2250			VDC
		Input (Output) to Case	1600			
Isolation resistance	500VDC		1			G Ω
Isolation capacitance					2500	pF
Switching frequency			225	250	275	kHz
Safety approvals						UL60950-1 EN60950-1 IEC60950-1
Case material						Metal
Base material						FR4 PCB
Potting material						Silicone (UL94 V-0)
Weight						105g (3.70oz)
MTBF	MIL-HDBK-217F, Full load					3.182 \times 10 ⁵ hrs

ENVIRONMENTAL SPECIFICATIONS

Parameter	Conditions	Min.	Typ.	Max.	Unit
Operating case temperature		-40		+115	°C
Over temperature protection			+120		°C
Storage temperature range	Terminal block type Others	-40 -55		+105 +125	°C
Thermal impedance ⁽³⁾	Vertical direction by natural convection (20LFM) Module without assembly option Only mount on the iron base-plate Heat-sink type with 0.24" Height Heat-sink type with 0.45" Height		6.1 2.8 5.1 4.6		°C/W
Thermal shock					MIL-STD-810F
Vibration					MIL-STD-810F
Relative humidity					5% to 95% RH

EMC SPECIFICATIONS

Parameter	Conditions	Level
EMI ⁽⁴⁾	EN55022	Class A Class B
ESD	EN61000-4-2 Air ±8kV and Contact ±6kV	Perf. Criteria A
Radiated immunity	EN61000-4-3 20V/m	Perf. Criteria A
Fast transient ⁽⁵⁾	EN61000-4-4 ±2kV	Perf. Criteria A
Surge ⁽⁵⁾	EN61000-4-5 EN55024 ±2kV	Perf. Criteria A
Conducted immunity	EN61000-4-6 10Vr.m.s	Perf. Criteria A

Note:

- Input source impedance: The power modules will operate as specifications without external components, assuming that the source voltage has a very low impedance and reasonable input voltage regulation. Highly inductive source impedances can affect the stability of the power module. Since real-world voltage source has finite impedance, performance can be improved by adding external filter capacitor. Recommended Nippon Chemi-con KY series, 100µF/100V.
- (1) Multiple HAE200 series module can be synchronized together simply by connecting Sync pins together. Care should be taken to ensure the ground potential differences between modules are minimized.
(2) In this configuration all of the modules will be synchronized to the highest frequency module.
(3) Up to three modules can be synchronized using this technique.
(4) More relevant information in datasheet.
- (1) Thermal test condition with vertical direction by natural convection (20LFM).
(2) The iron base-plate dimension is 19" X 3.5" X 0.063" (The height is EIA standard 2U).
(3) The heat-sink is optional and P/N: 7G-0021A-F, 7G-0022A-F, 7G-0023A-F, 7G-0024A-F. Please refer to heat-sink selection guide.
- The HAE200 series standard module meets EN55022 Class A and Class B with external components.
- An external input filter capacitor is required if the module has to meet EN61000-4-4, EN61000-4-5. Recommended 2 pcs of aluminum electrolytic capacitor (Nippon Chemi-con KY series, 220µF/100V) to connect in parallel.
- CASE GROUNDING : Connecting four screw bolts to shield plane will help to reduce the EMI.
- For further information, please contact with P-DUKE.

CAUTION: This power module is not internally fused. An input line fuse must always be used.

CHARACTERISTIC CURVE

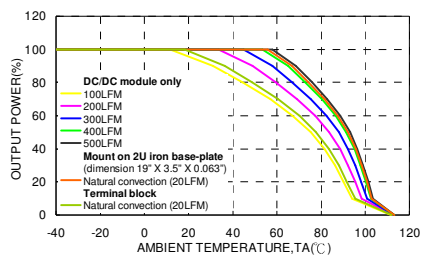

HAE200-48S05 Derating Curve (Note 3)

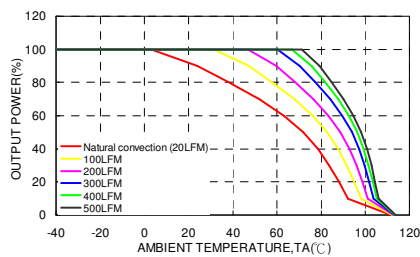

HAE200-48S05 Derating Curve (Note 3) With 0.24" Height Heat-sink

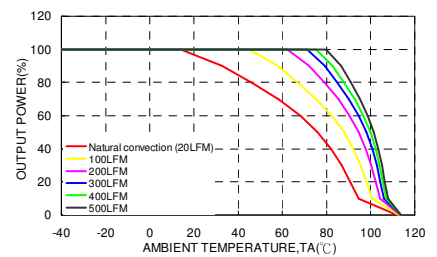

HAE200-48S05 Derating Curve (Note 3) With 0.45" Height Heat-sink

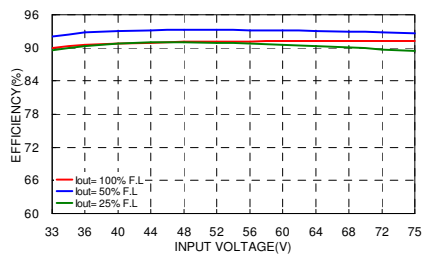

HAE200-48S05 Efficiency vs. Input Voltage

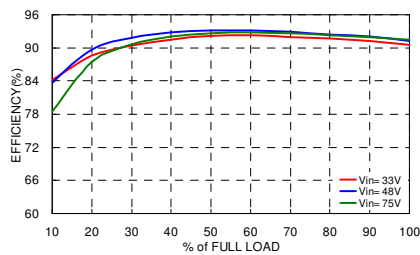

HAE200-48S05 Efficiency vs. Output Load

MECHANICAL DRAWING

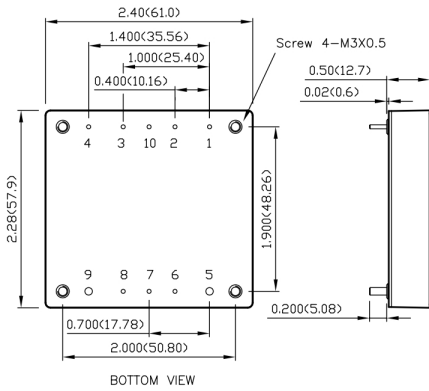

1. All dimensions in inch (mm)
2. Tolerance :x.xx±0.02 (x.x±0.5)
x.xxx±0.01 (x.xx±0.25)
3. Pin pitch tolerance ±0.01 (0.25)
4. Pin dimension tolerance ±0.004(0.1)
5. Mounting screws should always be used.
6. The screw locked torque:
MAX 5.0kgf-cm(0.49N-m)

PIN CONNECTION

PIN	DEFINE	DIAMETER
1	-Vin	0.04 Inch
2	Case (option)	0.04 Inch
3	Ctrl	0.04 Inch
4	+Vin	0.04 Inch
5	-Vout	0.08 Inch
6	-Sense	0.04 Inch
7	Trim	0.04 Inch
8	+Sense	0.04 Inch
9	+Vout	0.08 Inch
10	Sync (option)	0.04 Inch

EXTERNAL OUTPUT TRIMMING

Output can be externally trimmed by using the method shown below.

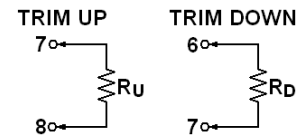

$$R_U = \left(\frac{V_{OUT} (100 + \Delta\%)}{1.225 \Delta\%} - \frac{(100 + 2\Delta\%)}{\Delta\%} \right) k\Omega$$

$$R_D = \left(\frac{100}{\Delta\%} - 2 \right) k\Omega$$

HEAT-SINK TYPE OPTIONS

Vertical Fin Orientation, Suffix:-HS, -HS2

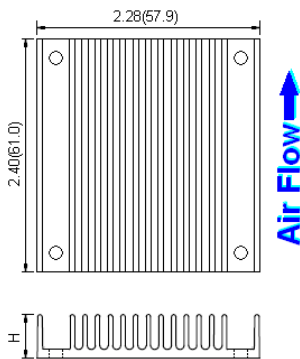

Horizontal Fin Orientation, Suffix:-HS1, -HS3

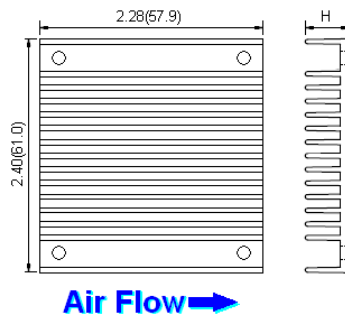

HS:	Height H=0.45" vertical fin, 7G-0021A-F
HS1:	Height H=0.24" horizontal fin, 7G-0022A-F
HS2:	Height H=0.24" vertical fin, 7G-0023A-F
HS3:	Height H=0.45" horizontal fin, 7G-0024A-F

1. All dimensions in inch (mm)
2. Tolerance :x.xx±0.02 (x.x±0.5)
x.xxx±0.01 (x.xx±0.25)

TERMINAL BLOCK TYPE OPTION

Wall mounted, Suffix: -T

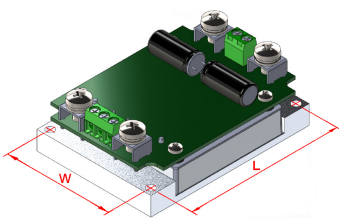

Wall mounted with EMC Filter, Suffix: -TF

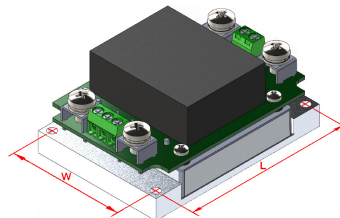

Wall mounted with EMC Filter, Suffix: -TF1
(Can be connected to PE Ⓢ)

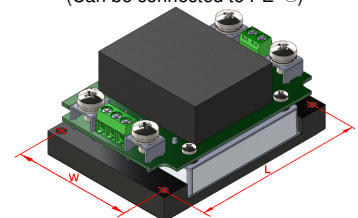

Terminal block type	-T	-TF	-TF1
Weight	235g (8.29oz)	280g (9.88oz)	287g (10.12oz)
Dimensions	3.35 x 2.40 x 1.27 inch (85.0 x 61.0 x 32.3 mm)	3.35 x 2.40 x 1.47 inch (85.0 x 61.0 x 37.3 mm)	3.35 x 2.40 x 1.53 inch (85.0 x 61.0 x 38.8 mm)
Through hole (W×L)	2.126 x 3.071 inch (54.00 x 78.00 mm), 4-φ 0.17 inch (φ 4.3mm)		

For further information, please contact with P-DUKE.