

BTA41 Series
40A TRIACs
3 Quadrants
4 Quadrants

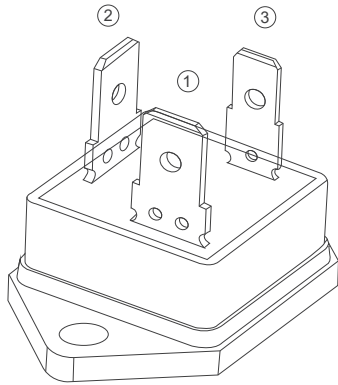

TG-C

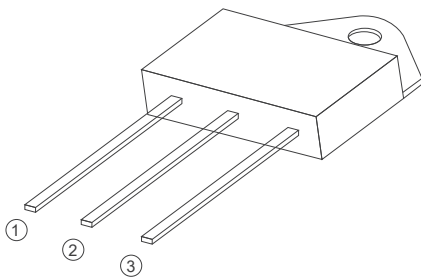

TO-3P Insulated

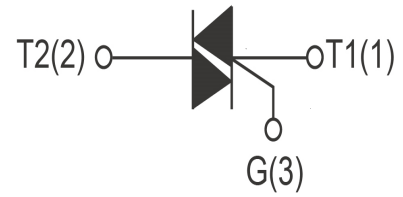

FEATURES

> IT(RMS): 40A > VGT: <1.5V > VDRM VRRM:600V~1600V

APPLICATIONS

Washing machine,vacuums, massager,solid state relay, AC Motor speed regulation and so on.

Absolute Maximum Ratings (T_J=25°C unless otherwise specified)

Symbol	Parameter	Conditions	Ratings	Unit
V _{DRM} V _{RRM}	Repetitive Peak Off-State Voltage	BTA41-600	600	V
		BTA41-800	800	
		BTA41-1200	1200	
		BTA41-1600	1600	
V _{DSM}	Non repetitive surge peak Off state voltage	tp=20ms T _J =25°C	V _{DRM} +100	V
V _{RSM}	Non repetitive peak reverse voltage	tp=20ms T _J =25°C	V _{RRM} +100	V
I _{T(RMS)}	R.M.S On-State Current	T _c = 80°C	40	A
I _{ISM}	Surge On-State Current	tp=16.7ms/tp=10ms	400/420	
I ² t	I ² t for fusing	T _p =10ms	880	A ² s
PG(AV)	Average Gate Power Dissipation	T _J =150°C	1	W
IGM	Peak Gate Current	T _J = 150°C	4	A
T _J	Operating Junction Temperature		~40~150	°C
TSTG	Storage Temperature		~40~150	

Electrical Characteristics (T_J=25°C unless otherwise specified)

Symbol	Parameter	Test Conditions	BW	B	Unit
IDRM	Repetitive Peak Off-State Current	T _J =25°C	5		uA
		T _J = 150°C	5		mA
IRRM	Repetitive Peak Reverse Current	T _J =25°C	5		uA
		T _J =150°C	5		mA
VTM	Forward "on" voltage	I _T =60A, tp=380us	1.55		V
VGT	Gate trigger voltage	V _D =12V ,R _L =30Ω	≤1.5		V
di/dt	V _D =2/3V _{DRM} Gate Open, T _J = 150°C I,II,III,IV	F=100Hz, I _G =2xI _{GT} , tr≤100ns	50		A/us
IGT	Gate trigger current	I,II,III VD=12V, RL=30Ω	≤50	≤50	mA
			/	≤100	
I _H	Holding current	I _T =0.2A	≤60	≤80	
V _{GD}	Gate non-trigger voltage	V _D =V _{DRM} , T _J =150°C,R _L =3.3KΩ	0.2		V
dv/dt	Critical-rate of rise of commutation voltage	T _J =150°C V _D =2/3V _{DRM} , Gate open circuit	≥1500	≥1000	V/us

FIG1

Maximum power dissipation versus RMS on-state current

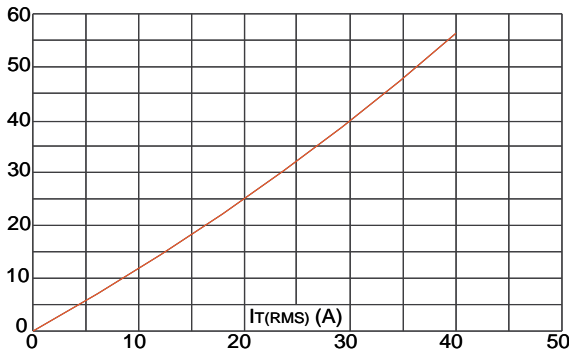

FIG2

RMS on-state current versus case temperature

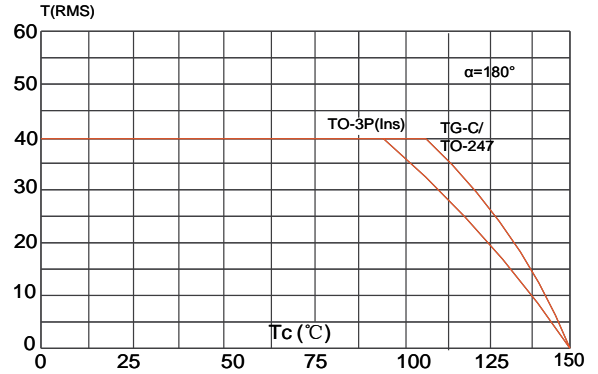

FIG3

Surge peak on-state current versus number of cycles

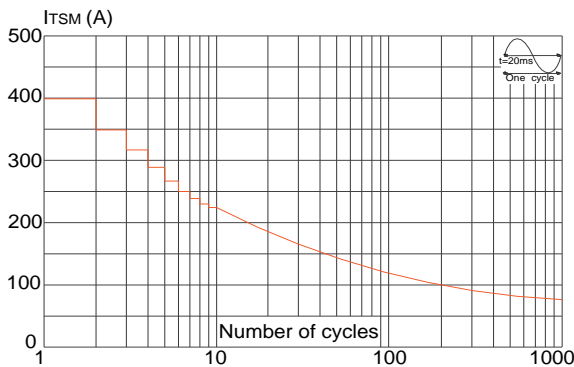

FIG4

On-state characteristics (maximum values)

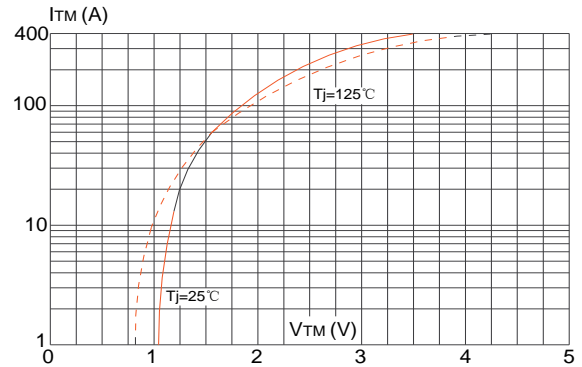

FIG5

Non-repetitive surge peak on-state current for a sinusoidal pulse with width $t_p < 20\text{ms}$, and corresponding value of I^2t ($di/dt < 100\text{A}/\mu\text{s}$)

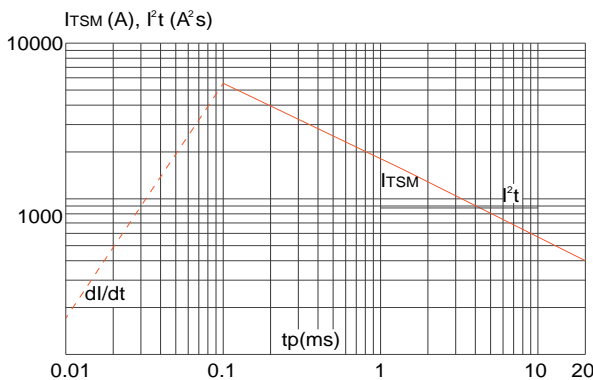
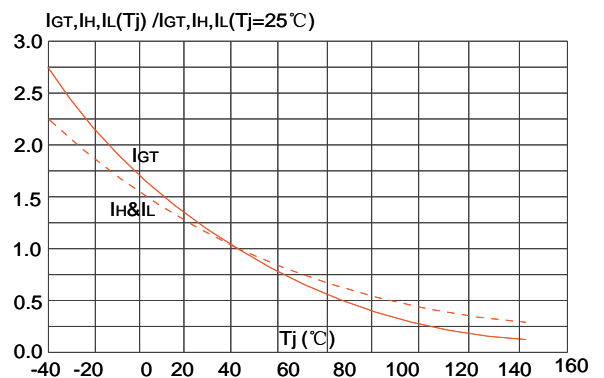
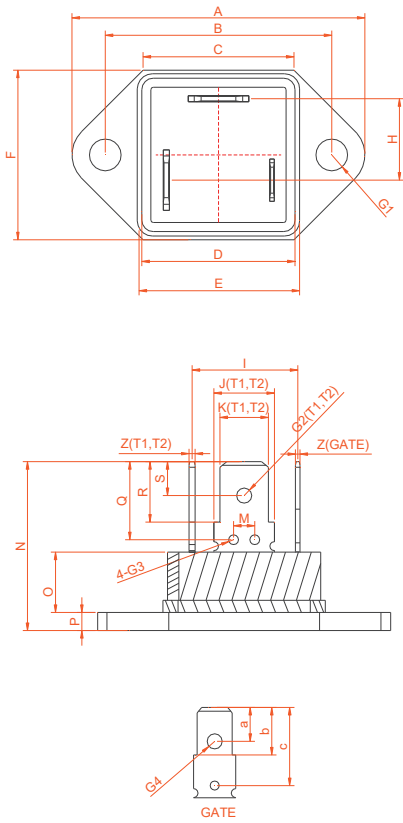

FIG6

FIG.6: Relative variations of gate trigger current, holding current and latching current versus junction temperature



PACKAGE MECHANICAL DATA



TG-C

Ref.	Dimensions					
	Millimeters			Inches		
	Min.	Typ.	Max.	Min.	Typ.	Max.
A			39.2			1.543
B	29.8	30.0	30.2	1.173	1.181	1.189
C			21.6			0.85
D			20.2			0.795
E			20.5			0.791
F			23			0.906
T1、T2		8.10			0.318	
T3		5.65			0.222	
T'		6.35			0.25	
t1、t2		0.8			0.031	
t3		0.6			0.023	
G		13.9			0.547	
H1		2.6			0.102	
H2		10.8			0.425	
H			22.8			0.886
h1	6.2	6.35	6.5	0.244	0.25	0.256
h2	7.8	7.95	8.1	0.307	0.313	0.319
h3	9.45	9.75	10.05	0.372	0.384	0.396
I	2.7	3.0	3.3	0.106	0.118	0.130
J		10.8			0.425	

Ref.	Dimensions					
	Millimeters			Inches		
	Min.	Typ.	Max.	Min.	Typ.	Max.
A	4.40		4.60	0.173		0.181
B	1.45		1.55	0.057		0.061
C	14.35		15.60	0.565		0.614
D	0.50		0.70	0.020		0.028
E	2.70		2.90	0.106		0.114
F	15.80		16.50	0.622		0.650
G	20.40		21.10	0.803		0.831
H	15.10		15.50	0.594		0.610
J	5.40		5.65	0.213		0.222
K	1.10		1.40	0.043		0.055
L	1.25		1.45	0.049		0.057
P	2.80		3.00	0.110		0.118
R		4.35			0.171	
M	12.37		12.77	0.487		0.503

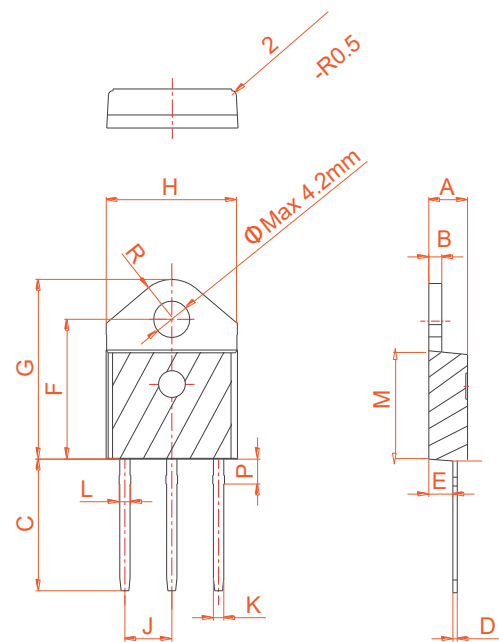

TO-3P Ins



Information furnished is believed to be accurate and reliable. However, Shenzhen HanKingyuan Electronic assumes no responsibility for the consequences of use of such information nor for any infringement of patents or other rights of third parties which may result from its use. Specifications mentioned in this publication are subject to change without notice. This publication supersedes and replaces all information previously supplied.

The KY logo is a registered trademark of Shenzhen HanKingyuan Electronic.

©2013 Shenzhen HanKingyuan Electronic - Printed in Shenzhen - All Rights Reserved